

# BANSHEE™

*"IT'S NOT A BATTERY, IT'S A BANSHEE"*

## LITHIUM-ION MARINE

Advanced LiFePO4 Technology

### Performance

Voltage	12V
Capacity (20-hour)	70Ah
Cold Cranking Amps (EN1)	900A

### Dimensions

Length	305mm
Width	173mm
Height	200mm
Total Height	220mm

### Weights & Measures

Weight	18.80 lbs
--------	-----------



### Container Features

Case Type	27M BCI Group
Cell Layout	1
Hold Down	B0
Handles	✓
End Venting	✓
Semi-Traction Features	✓
LED voltmeter	✓
MBS	✓

Technology	Lithium Iron Phosphate (LiFePO4)
Continuous discharge current	100A
Starting & Deep Cycle	
Lid Type	SMF Double Lid
Case	Black-ABS Material
Cover	Black-PP Material
Handle	Black-PP Material

### Terminal Type

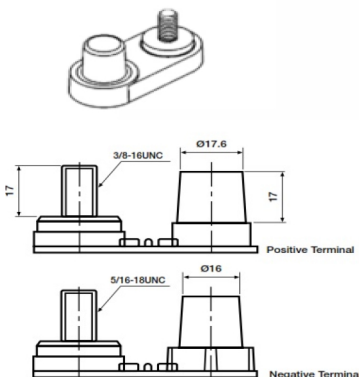

### Cell Assembly Layout

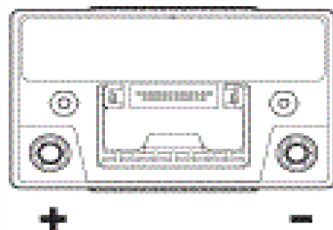

### Battery Hold-down

